



## Opti Max3100 1 GHz 2 x 2 Segmentable Node Technical Specification

### Opti Max3100 (42/54 MHz Split) Node Specifications

Characteristic	Specification
<b>General Node Specifications</b>	
Number of Active RF/AC Ports	4 (3 for 1 x 3 RF module)
Number of AC Only Ports	2 (1 for 1 x 3 RF module)
Housing Passband, MHz	1002
Port Impedance, $\Omega$	75
AC Current Passing, A (All Ports)	15
Operating Temperature Range, $^{\circ}\text{C}$	-40 to 60
<b>Forward Path Specifications</b>	
<b>Optical Specifications</b>	
Optical Input Wavelength, nm	1290 to 1600
Optical Input Range, dBm <sup>1</sup>	-3 to 3
<b>RF Specifications</b>	
Operating Passband, MHz	54 to 1002
Output Level @ 1002 MHz, -3 dBm input, 3.5% OMI, dBmV, min.	53.5
Level Stability, dB, max.	$\pm 1.5$
Gain Slope, dB <sup>2</sup>	9.5, 11.5, 12.5, 14.5, 16.5 $\pm 1.0$
Flatness @ Gain Slope, dB	$\pm 1.5$
Return Loss, dB, min. (All RF Ports)	16.0
Port to Port Isolation, dB, typ.	60
Testpoints	
Forward Output, Directional, dB	-20 $\pm$ 0.75
Receiver (NOR) Input Optical Level Testpoint	1V/mW $\pm$ 10%
<b>79 NTSC Channel Performance<sup>3,4</sup></b>	
Frequency, MHz	1002/870/550/54
Output Level, dBmV <sup>5</sup>	53.5/51.2/45.7/37
Carrier to Noise Ratio, 4 MHz, 75 $\Omega$ , dB	57, 0 dBm input
Composite Triple Beat, -dBc	73
Composite 2IM, -dBc	67

**Opti Max3100 (42/54 MHz Split) Node Specifications (Continued)**

Characteristic	Specification
Cross Modulation, per NCTA std., -dB	70
Composite Intermodulation Noise, dB <sup>6</sup>	62.5
Composite Intermodulation Noise, dB <sup>7</sup>	68.5
Chrominance to Luminance Delay	
Channel 2, ns max./3.58MHz	20
Channel 3, ns max./3.58MHz	10
Channel 4, ns max./3.58MHz	7
Channel 5, ns max./3.58MHz	4
Hum Modulation (Time Domain @ 15A)	
54 to 1002MHz, dB	60
Gain Control, plug-in PADs <sup>8</sup>	10-Ax-WC (0-26dB); 9-A0 to 9-A9 in 0.5 dB steps
Equalization <sup>8</sup>	
1 GHz	GEQL-1GHZ-000-1 (0dB), GEQL-1GHZ-020-1 to GEQL-1GHZ-130-1 (2-13 dB)
870MHz	GEQL-870-020-1 to GEQL-870-130-1 (2-13 dB)
<b>Return Path Specifications</b>	
<b>RF Specifications</b>	
Operating Passband, MHz	5 to 42
Optimum RF Input Level, dBmV/6MHz	12
Gain Slope, dB	±1.0
Flatness @ Gain Slope, dB	±1.0
RF Stability, dB	±2.5
Return Loss, dB (All RF Ports)	16.0
Port to Port Isolation, dB, typ.	50
Testpoints	
RF Input, Directional, dB	-20 ± 0.75
Transmitter Output Optical Power	1V/mW ± 10%
Group Delay	
5.5 to 7MHz, ns, max.	62
38.5 to 40MHz, ns, max.	20
Hum Modulation (Time Domain @ 15A)	
5 to 10MHz, dB	55
11 to 42MHz, dB	60
Gain Control, plug-in PADs <sup>8</sup>	9-A0-WC to 9-A19.5-WC (0-19.5 dB, in 0.5 dB steps) or Amini-0 to Amini-20 (0 to 20dB, in 1 dB steps)
<b>Opti Max3100 w/ Isolated 1310 DFB and 1550 DFB TX Specifications</b>	
Transmitted Wavelength, nm	1310 ± 20, 1550 ± 25
Output Power, @ connector output, dBm <sup>9</sup>	3.0 ± 1.0
NPR/Dynamic Range, dB <sup>10</sup>	41/12
Peak NPR, dB, typ. <sup>10</sup>	48
BER Dynamic Range, QPSK/16-QAM, dB <sup>10,11</sup>	45/35
<b>Opti Max3100 w/ Isolated CWDM DFB Analog TX Specifications</b>	
Transmitted Wavelength, nm	1471 to 1611 ± 6.5nm (8 CWDM channels, 20nm spacing)
Output Power, @ connector output, dBm <sup>9</sup>	3.0 ± 1.0

**Opti Max3100 (42/54 MHz Split) Node Specifications (Continued)**

Characteristic	Specification			
NPR/Dynamic Range, dB <sup>10</sup>	35/15			
Peak NPR, dB, typ. <sup>10</sup>	45			
BER Dynamic Range, QPSK/16-QAM, dB <sup>10,11</sup>	45/35			
Powering Requirements <sup>12</sup>	DC Curr. (mA, max.)	DC Pwr	AC I/P Curr.	AC I/P Pwr
	24V	(W)	@ 60/90V (A)	(W)
1 x 3/4 x 1 w/ 1310/1550 new DFB NRT	2.175	52.2	1.09/0.806	59.3
1 x 3/4 x 1 w/ 1310 legacy DFB NRT	2.4	57.6	1.21/0.866	65.1
1 x 3/4 x 1 w/ 1310/1550 CWDM DFB NRT	2.55	61.2	1.292/0.905	69.1
1 x 3 Redundant w/ 1310/1550 new DFB NRT	2.725	65.4	1.38/0.956	73.6
1 x 3 Redundant w/ 1310 legacy DFB NRT	3.175	76.2	1.624/1.09	85.6
1 x 3 Redundant w/ 1310/1550 CWDM NRT	3.475	83.4	1.79/1.183	93.6
1 x 4/4 x 1 w/ 1310/1550 new DFB NRT	2.71	65.04	1.28/0.85	76.52
1 x 4/4 x 1 w/ 1310 legacy DFB NRT	2.93	70.32	1.38/0.92	82.73
1 x 4/4 x 1 w/ 1310/1550 CWDM DFB NRT	3.08	73.92	1.45/0.97	86.96
1 x 4/4 x 1 Redundant w/ 1310/1550 new DFB NRT	3.21	77.04	1.51/1.01	90.64
1 x 4/4 x 1 Redundant w/ 1310 legacy DFB NRT	3.66	87.84	1.72/1.15	103.34
1 x 4/4 x 1 Redundant w/ 1310/1550 CWDM NRT	3.96	95.04	1.86/1.24	111.81
2 x 2 w/ 1310/1550 new DFB NRT	3.41	81.84	1.60/1.07	96.28
2 x 2 w/ 1310 legacy DFB NRT	3.86	92.64	1.82/1.21	108.99
2 x 2 w/ 1310/1550 CWDM NRT	4.16	99.84	1.96/1.31	117.46

Specification Document Number 1502422 Rev D, 1504410 Rev B

1. Circuit resiliency to 5 dBm.
2. Typical slope is 6.5 dB with no EQ installed. Slope is defined as the difference between the highest and lowest specified frequency on a straight line determined by applying a best fit/least squared formula to the measured response.
3. The distortion values listed are for the node only. To obtain a particular link performance, combine the listed node performance values with the applicable transmitter performance values.
4. Analog channels occupying the 54 to 550 MHz frequency range with digitally compressed channels or equivalent broadband noise to 1002 MHz at levels 6 dB below equivalent video channels.
5. At the specified operational tilt of 16.5 dB, the maximum output level for 870 MHz or 1002 MHz loading is 56.5 dBmV at the highest frequency.
6. Systems operating with digitally compressed channels or equivalent broadband noise from 550 to 1002 MHz at levels 6 dB below equivalent video channels will experience a composite distortion (CIN) appearing as noise in the 54 to 550 MHz frequency spectrum.
7. Systems operating with digitally compressed channels or equivalent broadband noise from 550 to 870 MHz at levels 6 dB below equivalent video channels will experience a composite distortion (CIN) appearing as noise in the 54 to 550 MHz frequency spectrum.
8. ARRIS accessories should be used for guaranteed performance; using third party accessories may result in degraded and/or intermittent performance.
9. Measured at the output of the bulkhead connector.
10. All performance specifications measured over a 6 dB (pure glass) fiber link using 40 MHz noise loading with an optical receiver causing no degradation to performance.
11. Bit Error Rate (BER) performance is measured with QPSK loading over 6 dB pure fiber link for a BER of 10<sup>-6</sup>. All measurements are typical.
12. DC current draw requirements for Value Max transponder and daughter card: add 55 mA @ 24V. All values assume the use of a 1 GHz NOR receiver; the use of a legacy NOR will increase the DC current draw by 140 mA each.

## Opti Max3100 (55/70MHz Split) Node Specifications

Characteristic	Specification
<b>General Node Specifications</b>	
Number of Active RF/AC Ports	4
Number of AC Only Ports	1 (Optional)
Housing Passband, MHz	1002
Port Impedance, $\Omega$	75
AC Current Passing, A (All Ports)	15
Operating Temperature Range, $^{\circ}\text{C}$	-40 to 60
<b>Forward Path Specifications</b>	
<b>Optical Specifications</b>	
Optical Input Wavelength, nm	1290 to 1600
Optical Input Range, dBm <sup>1</sup>	-3 to 3
<b>RF Specifications</b>	
Operating Passband, MHz	70 to 1002
Output Level @ 1002MHz, -3 dBm input, 3.5% OMI, dBmV, min.	53.5
Level Stability, dB, max.	$\pm 1.5$
Gain Slope, dB <sup>2</sup>	9.5, 11.5, 12.5, 14.5, 16.5 $\pm 1.0$
Flatness @ Gain Slope, dB	$\pm 1.5$
Return Loss, dB, min. (All RF Ports)	16.0
Port to Port Isolation, dB, typ.	60
Testpoints	
Forward Output, Directional, dB	-20 $\pm$ 0.75
NOR Input Optical Level	1V/mW $\pm$ 10%
<b>76 NTSC Channel Performance<sup>3,4</sup></b>	
Frequency, MHz	1002/870/550/70
Output Level, dBmV <sup>5</sup>	53.5/51.2/45.5/37
Carrier to Noise Ratio, 4MHz, 75 $\Omega$ , dB	57, 0dBm input
Composite Triple Beat, -dBc	73
Composite 2IM, -dBc	67
Cross Modulation, per NCTA std., -dB	70
Composite Intermodulation Noise, dB <sup>6</sup>	62.5
Composite Intermodulation Noise, dB <sup>7</sup>	68.5
Chrominance to Luminance Delay	
Channel 5, ns max./3.58MHz	9
Channel 6, ns max./3.58MHz	7
<b>Hum Modulation (Time Domain @ 15A)</b>	
70 to 1002MHz, dB	60
Gain Control, plug-in PADS <sup>8</sup>	10-Ax-WC (0-26dB); 9-A0 to 9-A9 in 0.5dB steps (NOR)
Equalization <sup>8</sup>	2-13dB

**Opti Max3100 (55/70MHz Split) Node Specifications (Continued)**

Characteristic	Specification			
<b>Return Path Specifications</b>				
<b>RF Specifications</b>				
Operating Passband, MHz	5 to 55			
Optimum RF Input Level, dBmV/6MHz	12			
Gain Slope, dB	±1.0			
Flatness @ Gain Slope, dB	±1.0			
RF Level Stability, dB	±2.5			
Return Loss, dB (All RF Ports)	16.0			
Port to Port Isolation, dB, typ.	50			
Testpoints				
RF Input, Directional, dB	-20 ± 0.75			
Transmitter Output Optical Power	1V/mW ± 10%			
Group Delay				
5.5 to 7MHz, ns, max.	62			
53.5 to 55MHz, ns, max.	15			
Hum Modulation (Time Domain @ 15 A)				
5 to 10MHz, dB	55			
11 to 55MHz, dB	60			
Gain Control, plug-in PADS <sup>8</sup>	10-Ax-WC (0–20dB)			
<b>Opti Max3100 w/ Isolated 1310 DFB and 1550 DFB TX Specifications</b>				
Transmitted Wavelength, nm	1310 ± 20, 1550 ± 25			
Output Power, @ connector output, dBm <sup>9</sup>	3.0 ± 1.0			
NPR/Dynamic Range, dB <sup>10</sup>	35/13			
Peak NPR, dB, typ. <sup>10</sup>	45			
BER Dynamic Range, QPSK/16-QAM, dB <sup>10,11</sup>	43/33			
<b>Opti Max3100 w/ Isolated CWDM DFB Analog TX Specifications</b>				
Transmitted Wavelength, nm	1471 to 1611 ± 6.5nm (8 CWDM channels, 20nm spacing)			
Output Power, @ connector output, dBm <sup>9</sup>	3.0 ± 1.0			
NPR/Dynamic Range, dB <sup>10</sup>	35/13			
Peak NPR, dB, typ. <sup>10</sup>	45			
BER Dynamic Range, QPSK/16-QAM, dB <sup>10,11</sup>	43/33			
<b>Powering Requirements<sup>12</sup></b>	<b>DC Curr. (mA, max.)</b>	<b>DC Pwr</b>	<b>AC I/P Curr.</b>	<b>AC I/P Pwr</b>
	<b>24V</b>	<b>(W)</b>	<b>@ 60/90V (A)</b>	<b>(W)</b>
1 x 3/4 x 1 w/ 1310/1550 new DFB NRT	2.175	52.2	1.09/0.806	59.3
1 x 3/4 x 1 w/ 1310 legacy DFB NRT	2.4	57.6	1.21/0.866	65.1
1 x 3/4 x 1 w/ 1310/1550 CWDM DFB NRT	2.55	61.2	1.292/0.905	69.1
1 x 3 Redundant w/ 1310/1550 new DFB NRT	2.725	65.4	1.38/0.956	73.6
1 x 3 Redundant w/ 1310 legacy DFB NRT	3.175	76.2	1.624/1.09	85.6
1 x 3 Redundant w/ 1310/1550 CWDM NRT	3.475	83.4	1.79/1.183	93.6
1 x 4/4 x 1 w/ 1310/1550 new DFB NRT	2.71	65.04	1.28/0.85	76.52
1 x 4/4 x 1 w/ 1310 legacy DFB NRT	2.93	70.32	1.38/0.92	82.73
1 x 4/4 x 1 w/ 1310/1550 CWDM DFB NRT	3.08	73.92	1.45/0.97	86.96
1 x 4/4 x 1 Redundant w/ 1310/1550 new DFB NRT	3.21	77.04	1.51/1.01	90.64
1 x 4/4 x 1 Redundant w/ 1310 legacy DFB NRT	3.66	87.84	1.72/1.15	103.34

**Opti Max3100 (55/70 MHz Split) Node Specifications (Continued)**

Characteristic	Specification			
1 x 4/4 x 1 Redundant w/ 1310/1550 CWDM NRT	3.96	95.04	1.86/1.24	111.81
2 x 2 w/ 1310/1550 new DFB NRT	3.41	81.84	1.60/1.07	96.28
2 x 2 w/ 1310 legacy DFB NRT	3.86	92.64	1.82/1.21	108.99
2 x 2 w/ 1310/1550 CWDM NRT	4.16	99.84	1.96/1.31	117.46

Specification Document Number 1504910 Rev B

1. Circuit resiliency to 5dBm.
2. Typical slope is 6.5dB with no EQ installed. Slope is defined as the difference between the highest and lowest specified frequency on a straight line determined by applying a best fit/least squared formula to the measured response.
3. The distortion values listed are for the node only. To obtain a particular link performance, combine the listed node performance values with the applicable transmitter performance values.
4. Analog channels occupying the 70 to 550MHz frequency range with digitally compressed channels or equivalent broadband noise to 1002MHz at levels 6dB below equivalent video channels.
5. At the specified operational tilt of 16.5 dB, the maximum output level for 870MHz or 1002MHz loading is 56.5dBmV at the highest frequency.
6. Systems operating with digitally compressed channels or equivalent broadband noise from 550 to 1002MHz at levels 6dB below equivalent video channels will experience a composite distortion (CIN) appearing as noise in the 70 to 550MHz frequency spectrum.
7. Systems operating with digitally compressed channels or equivalent broadband noise from 550 to 870MHz at levels 6dB below equivalent video channels will experience a composite distortion (CIN) appearing as noise in the 70 to 550MHz frequency spectrum.
8. ARRIS accessories should be used for guaranteed performance; using third party accessories may result in degraded and/or intermittent performance.
9. Measured at the output of the bulkhead connector.
10. All performance specifications measured over a 6dB (pure glass) fiber link using 40MHz noise loading with an optical receiver causing no degradation to performance.
11. Bit Error Rate (BER) performance is measured with QPSK/16-QAM loading over 6dB pure fiber link for a BER of 10<sup>-6</sup>. All measurements are typical.
12. DC current draw requirements for Value Max transponder and daughter card: add 55 mA @ 24V. All values assume the use of a 1GHz NOR receiver; the use of a legacy NOR will increase the DC current draw by 140mA each.

**Opti Max3100 (65/85 MHz Split) General Node Specifications**

Characteristic	Specification
<b>General Node Specifications</b>	
Number of Active RF/AC Ports	4
Number of AC Only Ports	1 (Optional)
Housing Passband, MHz	1002
Port Impedance, $\Omega$	75
AC Current Passing, A (All Ports)	15
Operating Temperature Range, $^{\circ}\text{C}$	-40 to 60
<b>Forward Path Specifications</b>	
<b>Optical Specifications</b>	
Optical Input Wavelength, nm	1290 to 1600
Optical Input Range, $\text{dBm}^1$	-3 to 3
<b>RF Specifications</b>	
Operating Passband, MHz	85 to 1002
Output Level @ 1002MHz, -3 dBm input, 3.5% OMI, $\text{dBmV}$ , min.	53.5
Level Stability, dB, max.	$\pm 1.5$
Gain Slope, $\text{dB}^2$	9.5, 11.5, 12.5, 14.5, $16.5 \pm 1.0$
Flatness @ Gain Slope, dB	$\pm 1.5$
Return Loss, dB, min. (All RF Ports)	16.0
Port to Port Isolation, dB, typ.	60
Testpoints	
Forward Output, Directional, dB	$-20 \pm 0.75$
NOR Input Optical Level	$1\text{V/mW} \pm 10\%$
<b>60 PAL Channel Performance<sup>3,4</sup></b>	
Frequency, MHz	1002/600/85
Output Level, $\text{dBmV}^5$	53.5/46.3/37
Carrier to Noise Ratio, 5 MHz, $75\Omega$ , dB	57, 0dBm input
Composite Triple Beat, -dBc	73
Composite 2IM, -dBc	69
Cross Modulation (per NCTA standard), -dB	70
Composite Intermodulation Noise CIN, $\text{dB}^6$	63
<b>42 Channel CENELEC Performance<sup>7</sup></b>	
Frequency, MHz	870/85
Output Level, $\text{dBmV}$	53/45
Carrier to Noise Ratio, 5 MHz, $75\Omega$ , dB	49, 0dBm input
Composite Triple Beat, -dBc	62
Composite 2IM, -dBc	62
<b>Relative Chroma Delay</b>	
88.58 to 92.16MHz, ns	5
95.74 to 99.32MHz, ns	4
102.90 to 106.48MHz, ns	3
<b>Hum Modulation (Time Domain @ 15A)</b>	
85 to 1002MHz, dB	60

**Opti Max3100 (65/85 MHz Split) General Node Specifications (Continued)**

Characteristic	Specification
Gain Control, plug-in PADS <sup>8</sup>	10-Ax-WC (0–26 dB); 9-A0 to 9-A9 in 0.5 dB steps (NOR)
Equalization <sup>9</sup>	
1 GHz	GEQL-1GHZ-000-1 (0 dB), GEQL-1GHZ-020-1 to GEQL-1GHZ-130-1 (2–13 dB)
870 MHz	GEQL-870-020-1 to GEQL-870-130-1 (2–13 dB)
<b>Return Path Specifications</b>	
<b>RF Specifications</b>	
Operating Passband, MHz	5 to 65
Optimum RF Input Level, dBmV/6 MHz	12
Gain Slope, dB	±1.0
Flatness @ Gain Slope, dB	±1.0
RF Level Stability, dB	±2.5
Return Loss, dB (All RF Ports)	16.0
Port to Port Isolation, dB, typ.	50
Testpoints	
RF Input, Directional, dB	–20 ± 0.75
Transmitter Output Optical Power	1V/mW ± 10%
Group Delay	
5.5 to 7 MHz, ns, max.	62
63.5 to 65 MHz, ns, max.	15
Hum Modulation (Time Domain @ 15 A)	
5 to 10 MHz, dB	55
11 to 65 MHz, dB	60
Gain Control, plug-in PADS <sup>8</sup>	10-Ax-WC (0–20 dB)
<b>Opti Max3100 w/ Isolated 1310 DFB and 1550 DFB TX Specifications</b>	
Transmitted Wavelength, nm	1310 ± 20, 1550 ± 25
Output Power, @ connector output, dBm <sup>9</sup>	3.0 ± 1.0
NPR/Dynamic Range, dB <sup>10</sup>	39/12
Peak NPR, dB, typ. <sup>10</sup>	47
BER Dynamic Range, QPSK/16-QAM, dB <sup>10,11</sup>	43/33
<b>Opti Max3100 w/ Isolated CWDM DFB Analog TX Specifications</b>	
Transmitted Wavelength, nm	1471 to 1611 ± 6.5 nm (8 CWDM channels, 20 nm spacing)
Output Power, @ connector output, dBm <sup>9</sup>	3.0 ± 1.0
NPR/Dynamic Range, dB <sup>10</sup>	33/15
Peak NPR, dB, typ. <sup>10</sup>	44
BER Dynamic Range, QPSK/16-QAM, dB <sup>10,11</sup>	43/33

**Opti Max3100 (65/85 MHz Split) General Node Specifications (Continued)**

Characteristic	Specification			
	DC Curr. (mA, max.)	DC Pwr	AC I/P Curr.	AC I/P Pwr
	24V	(W)	@ 60/90V (A)	(W)
Powering Requirements <sup>12</sup>				
1 x 3/4 x 1 w/ 1310/1550 new DFB NRT	2.175	52.2	1.09/0.806	59.3
1 x 3/4 x 1 w/ 1310 legacy DFB NRT	2.4	57.6	1.21/0.866	65.1
1 x 3/4 x 1 w/ 1310/1550 CWDM DFB NRT	2.55	61.2	1.292/0.905	69.1
1 x 3 Redundant w/ 1310/1550 new DFB NRT	2.725	65.4	1.38/0.956	73.6
1 x 3 Redundant w/ 1310 legacy DFB NRT	3.175	76.2	1.624/1.09	85.6
1 x 3 Redundant w/ 1310/1550 CWDM NRT	3.475	83.4	1.79/1.183	93.6
1 x 4/4 x 1 w/ 1310/1550 new DFB NRT	2.71	65.04	1.28/0.85	76.52
1 x 4/4 x 1 w/ 1310 legacy DFB NRT	2.93	70.32	1.38/0.92	82.73
1 x 4/4 x 1 w/ 1310/1550 CWDM DFB NRT	3.08	73.92	1.45/0.97	86.96
1 x 4/4 x 1 Redundant w/ 1310/1550 new DFB NRT	3.21	77.04	1.51/1.01	90.64
1 x 4/4 x 1 Redundant w/ 1310 legacy DFB NRT	3.66	87.84	1.72/1.15	103.34
1 x 4/4 x 1 Redundant w/ 1310/1550 CWDM NRT	3.96	95.04	1.86/1.24	111.81
2 x 2 w/ 1310/1550 new DFB NRT	3.41	81.84	1.60/1.07	96.28
2 x 2 w/ 1310 legacy DFB NRT	3.86	92.64	1.82/1.21	108.99
2 x 2 w/ 1310/1550 CWDM NRT	4.16	99.84	1.96/1.31	117.46

Specification Document Number 1502439 Rev E

1. Circuit resiliency to 5dBm.
2. Typical slope is 6.5dB with no EQ installed. Slope is defined as the difference between the highest and lowest specified frequency on a straight line determined by applying a best fit/least squared formula to the measured response.
3. The distortion values listed are for the node only. To obtain a particular link performance, combine the listed node performance values with the applicable transmitter performance values.
4. Analog channels occupying the 70 to 550MHz frequency range with digitally compressed channels or equivalent broadband noise to 1002MHz at levels 6dB below equivalent video channels.
5. At the specified operational tilt of 16.5 dB, the maximum output level for 870MHz or 1002MHz loading is 56.5dBmV at the highest frequency.
6. Systems operating with digitally compressed channels or equivalent broadband noise from 600 to 1002MHz at levels 6dB below equivalent video channels will experience a composite distortion (CIN) appearing as noise in the 85 to 600MHz frequency spectrum.
7. According to EN50083-3, 42 CENELEC channel loading, with duplex filters and 8dB slope. Measured with 5% OMI, -6dBm optical input, 113dBμV (53dBmV) RF output level, no optical AGC.
8. ARRIS accessories should be used for guaranteed performance; using third party accessories may result in degraded and/or intermittent performance.
9. Measured at the output of the bulkhead connector.
10. All performance specifications measured over a 6dB (pure glass) fiber link using 40MHz noise loading with an optical receiver causing no degradation to performance.
11. Bit Error Rate (BER) performance is measured with QPSK/16-QAM loading over 6dB pure fiber link for a BER of 10<sup>-6</sup>. All measurements are typical.
12. DC current draw requirements for Value Max transponder and daughter card: add 55mA @ 24V. All values assume the use of a 1GHz NOR receiver; the use of a legacy NOR will increase the DC current draw by 140mA each.

**Opti Max3100 (85/105 MHz Split) General Node Specifications**

Characteristic	Specification
<b>General Node Specifications</b>	
Number of Active RF/AC Ports	4
Number of AC Only Ports	2
Housing Passband, MHz	1002
Port Impedance, $\Omega$	75
AC Current Passing, A (All Ports)	15
Operating Temperature Range, $^{\circ}\text{C}$	-40 to 60
<b>Forward Path Specifications</b>	
<b>Optical Specifications</b>	
Optical Input Wavelength, nm	1290 to 1600
Optical Input Range, dBm <sup>1</sup>	-3 to 3
<b>RF Specifications</b>	
Operating Passband, MHz	105 to 1002
Output Level @ 1002MHz, -3 dBm input, 3.5% OMI, dBmV, min.	53.5
Level Stability, dB, max.	$\pm 1.5$
Gain Slope, dB <sup>2</sup>	9.8, 11.5, 12.5, 14.5, 16.5 $\pm 1.0$
Flatness @ Gain Slope, dB	$\pm 1.5$
Return Loss, dB, min. (All RF Ports)	16.0
Port to Port Isolation, dB, typ.	60
Testpoints	
Forward Output, Directional, dB	-20 $\pm$ 0.75
NOR Input Optical Level	1V/mW $\pm$ 10%
<b>79 NTSC Channel Performance<sup>3,4</sup></b>	
Frequency, MHz	1002/870/550/105
Output Level, dBmV <sup>5</sup>	53.5/51.2/45.7/37.9
Carrier to Noise Ratio, 4MHz, 75 $\Omega$ , dB	57, 0dBm input
Composite Triple Beat, -dBc	73
Composite 2IM, -dBc	67
Cross Modulation, per NCTA std., -dB	70
Composite Intermodulation Noise, dB <sup>6</sup>	62.5
Composite Intermodulation Noise, dB <sup>7</sup>	68.5
<b>Chrominance to Luminance Delay</b>	
Channel 98, ns max./3.58MHz	15
Channel 99, ns max./3.58MHz	9
<b>Hum Modulation (Time Domain @ 15A)</b>	
105 to 1002MHz, dB	60
Gain Control <sup>8</sup>	
Plug-in PADS	10-Ax-WC (0-26dB); 9-A0 to 9-A9 in 0.5dB steps (NOR)
Equalization Control <sup>8</sup>	
1 GHz	GEQL-1GHZ-020-1 to GEQL-1GHZ-130-1 (2-13 dB)
870MHz	GEQL-870-020-1 to GEQL-870-130-1 (2-13 dB)

**Opti Max3100 (85/105 MHz Split) General Node Specifications (Continued)**

Characteristic	Specification
<b>Return Path Specifications</b>	
<b>RF Specifications</b>	
Operating Passband, MHz	5 to 85
Optimum RF Input Level, dBmV/6 MHz	12
Gain Slope, dB	±1.0
Flatness @ Gain Slope, dB	±1.0
RF Level Stability, dB	±2.5
Return Loss, dB (All RF Ports)	16.0
Port to Port Isolation, dB, typ.	50
Testpoints	
RF Input, Directional, dB	-20 ± 0.75
Analog Transmitter Output Optical Power	1V/mW ± 10%
Group Delay	
5.5 to 7 MHz, ns, max.	62
83.5 to 85 MHz, ns, max.	20
Hum Modulation (Time Domain @ 15A)	
5 to 10 MHz, dB	55
11 to 85 MHz, dB	60
Gain Control, plug-in PADS <sup>8</sup>	10-Ax-WC (0–26dB)
<b>Opti Max3100 w/ Isolated 1310 DFB and 1550 DFB TX Specifications</b>	
Transmitted Wavelength, nm	1310 ± 20, 1550 ± 25
Output Power, @ connector output, dBm <sup>9</sup>	3.0 ± 1.0
NPR/Dynamic Range, dB <sup>10</sup>	41/12
Peak NPR, dB, typ. <sup>10</sup>	48
BER Dynamic Range, 16-QAM, dB <sup>10,11</sup>	45/35
<b>Opti Max3100 w/ Isolated CWDM DFB Analog TX Specifications</b>	
Transmitted Wavelength, nm	1471 to 1611 ± 6.5nm (8 CWDM channels, 20nm spacing)
Output Power, @ connector output, dBm <sup>9</sup>	3.0 ± 1.0
NPR/Dynamic Range, dB <sup>10</sup>	35/15
Peak NPR, dB, typ. <sup>10</sup>	45
BER Dynamic Range, QPSK/16-QAM, dB <sup>10,11</sup>	45/35

**Opti Max3100 (85/105 MHz Split) General Node Specifications (Continued)**

Characteristic	Specification			
	DC Curr. (mA, max.) 24V	DC Pwr (W)	AC I/P Curr. @ 60/90V (A)	AC I/P Pwr (W)
1 x 3/4 x 1 w/ 1310/1550 new DFB NRT	2.175	52.2	1.09/0.806	59.3
1 x 3/4 x 1 w/ 1310 legacy DFB NRT	2.4	57.6	1.21/0.866	65.1
1 x 3/4 x 1 w/ 1310/1550 CWDM DFB NRT	2.55	61.2	1.292/0.905	69.1
1 x 3 Redundant w/ 1310/1550 new DFB NRT	2.725	65.4	1.38/0.956	73.6
1 x 3 Redundant w/ 1310 legacy DFB NRT	3.175	76.2	1.624/1.09	85.6
1 x 3 Redundant w/ 1310/1550 CWDM NRT	3.475	83.4	1.79/1.183	93.6
1 x 4/4 x 1 w/ 1310/1550 new DFB NRT	2.71	65.04	1.28/0.85	76.52
1 x 4/4 x 1 w/ 1310 legacy DFB NRT	2.93	70.32	1.38/0.92	82.73
1 x 4/4 x 1 w/ 1310/1550 CWDM DFB NRT	3.08	73.92	1.45/0.97	86.96
1 x 4/4 x 1 Redundant w/ 1310/1550 new DFB NRT	3.21	77.04	1.51/1.01	90.64
1 x 4/4 x 1 Redundant w/ 1310 legacy DFB NRT	3.66	87.84	1.72/1.15	103.34
1 x 4/4 x 1 Redundant w/ 1310/1550 CWDM NRT	3.96	95.04	1.86/1.24	111.81
2 x 2 w/ 1310/1550 new DFB NRT	3.41	81.84	1.60/1.07	96.28
2 x 2 w/ 1310 legacy DFB NRT	3.86	92.64	1.82/1.21	108.99
2 x 2 w/ 1310/1550 CWDM NRT	4.16	99.84	1.96/1.31	117.46

Specification Document Number 1506246 Rev A

1. Circuit resiliency to 5dBm.
2. Typical slope is 6.5dB with no EQ installed. Slope is defined as the difference between the highest and lowest specified frequency on a straight line determined by applying a best fit/least squared formula to the measured response.
3. The distortion values listed are for the node only. To obtain a particular link performance, combine the listed node performance values with the applicable transmitter performance values.
4. Analog channels occupying the 54 to 550MHz frequency range with digitally compressed channels or equivalent broadband noise to 1002MHz at levels 6dB below equivalent video channels.
5. At the specified operational tilt of 16.5dB, the maximum output level for 870MHz or 1002MHz loading is 56.5dBmV at the highest frequency.
6. Systems operating with digitally compressed channels or equivalent broadband noise from 550 to 1002MHz at levels 6dB below equivalent video channels will experience a composite distortion (CIN) appearing as noise in the 54 to 550MHz frequency spectrum.
7. Systems operating with digitally compressed channels or equivalent broadband noise from 550 to 870MHz at levels 6dB below equivalent video channels will experience a composite distortion (CIN) appearing as noise in the 54 to 550MHz frequency spectrum.
8. ARRIS accessories should be used for guaranteed performance; using third party accessories may result in degraded and/or intermittent performance.
9. Measured at the output of the bulkhead connector.
10. All performance specifications measured over a 6dB (pure glass) fiber link using 40MHz noise loading with an optical receiver causing no degradation to performance.
11. Bit Error Rate (BER) performance is measured with QPSK loading over 6dB pure fiber link for a BER of 10<sup>-6</sup>. All measurements are typical.
12. DC current draw requirements for Value Max transponder and daughter card: add 55mA @ 24V. All values assume the use of a 1GHz NOR receiver; the use of a legacy NOR will increase the DC current draw by 140mA each.

## OM3100 1 GHz Node NOR Specifications

Characteristic	Specification
<b>Optical Specifications</b>	
Optical Wavelength, nm	1290 to 1600
Optical Input Return Loss, dB, min.	45
Equivalent Noise Input, pA/Hz <sup>0.5</sup>	8
Optical Input Range, dBm <sup>1</sup>	-3 to 3
Optical Power Threshold Alarm Limits, dBm	User-settable: -10 to 0
<b>RF Specifications</b>	
Impedance, Ohms	75
Frequency Range, MHz	40 to 1002
RF Output Level, dBmV, min. <sup>2</sup>	22.5
Thermal Stability, dB <sup>3</sup>	± 1.5
Slope, dB	± 0.5
Flatness, dB <sup>4</sup>	± 0.6
Return Loss, dB min.	14.0
<b>Testpoint Specifications</b>	
Output RF Testpoint, dB	-30 ± 1.0
Optical Power Monitor	1V/mW ± 10%
Optical Threshold Testpoint	10V <sub>DC</sub> = 1 mW
<b>79 NTSC Channel Performance Specifications @ Recommended Levels, typ.<sup>5</sup></b>	
Channels, Number of NTSC <sup>6</sup>	79
Frequency, MHz	1002/870/550/54
Output Level, dBmV	22.5/22.5/22.5/22.5
Carrier to Noise Ratio, 4 MHz, 75 Ohm, dB	57
Composite Triple Beat, -dBc	86
Cross Modulation, per NCTA std., -dB	81
Composite 2IM, -dBc	82
Composite Intermodulation Noise CIN, dB <sup>6</sup>	62
<b>LED Indicators</b>	
<b>OPT ALM</b> , Optical Power Threshold LED	Red: optical input below threshold
<b>PWR</b> , DC Power LED	Green: DC power okay Off: DC power failure
<b>Powering Requirements</b>	
Supply Voltages, VDC	24
DC Current, mA, max.	365
Power Consumption, W, max.	8.7

### OM3100 1 GHz Node NOR Specifications (Continued)

Characteristic	Specification
<b>Environmental Specifications</b>	
Operating Temperature, °C <sup>7</sup>	-20 to 85
Storage Temperature, °C	-40 to 85
Relative Operating Humidity, %, noncondensing	95
<b>Gain Control</b>	
Plug-in PADS <sup>8</sup>	9-A0 to 9-A19.5 (0–19.5 dB, in 0.5 dB steps)

Specification Document Number 1502438 Rev C

1. Circuit resiliency to +5 dBm.
2. RF output level is 22.5 dBmV minimum @ 1002 MHz with a -3.0 dBm received power, transmitter OMI of 3.5%, and a 0 dB PAD installed in Rx at **9-Axx ATTN** location.
3. The receiver module is designed to operate in a node application with external ambient temperature ranging from -40°C to 60°C.
4. Flatness is measured with respect to slope.
5. The distortion values listed are for the NOR only. To obtain a particular link performance, combine the listed NOR performance values with the applicable NRT performance values.
6. Systems operating with digitally compressed channels or equivalent broadband noise from 550 to 1002 MHz at levels 6 dB below equivalent video channels will experience a composite distortion (CIN) appearing as noise in the 54 to 550 MHz frequency spectrum. Distortion values are typical with an input of 0 dBm @ 3.5% OMI.
7. The NOR is designed to operate in a node application with external ambient temperature ranging from -40 to 60°C.
8. ARRIS accessories should be used for guaranteed performance; using third party accessories may result in degraded and/or intermittent performance.

### OM3100 NRT Analog Return Transmitter Specifications

Characteristic	Specification		
<b>Optical Specifications</b>	<b>NRT-1310-DFB</b>	<b>NRT-1550-DFB</b>	<b>NRT-xxxxCWDM</b>
Output Power, dBm <sup>1</sup>	3 ± 1	3 ± 1	3 ± 1
Transmitted Wavelength, nm	1310 ± 20	1550 ± 25	1471, 1491, 1511, 1531, 1551, 1571, 1591, 1611; ± 6.5
Laser Type, Isolated Uncooled	DFB	DFB	DFB
Optical Power Voltage Testpoint	1 mW/V ± 10%	1 mW/V ± 10%	1 mW/V ± 10%
Optical Connector Types	SC/APC, FC/APC	SC/APC, FC/APC	SC/APC, FC/APC
<b>RF Specifications</b>			
Impedance, Ohms	75	75	75
RF Bandpass, MHz	5 to 200	5 to 200	5 to 200
Return Loss, dB <sup>2,3</sup>	-16	-16	-16
Connector Type (75 ohm jack)	mini-SMB	mini-SMB	mini-SMB
RF Testpoint Insertion Loss, dB <sup>4</sup>	9.0 ± 0.5	9.0 ± 0.5	9.0 ± 0.5
Flatness, dB, max. <sup>5</sup>	±0.75	±0.75	±0.75
Gain Slope, dB, max. <sup>5</sup>	±0.5	±0.5	±0.5
RF Level Stability Over Temp., dB	±2.5	±2.5	±3.0
Manual Gain Control Range, dB	>8	>8	>8
Reverse Spurious, dBc	<-50	<-50	<-50
Operating Temperature, °C <sup>6</sup>	-30 to 85	-30 to 85	-30 to 85
<b>Powering Specifications</b>			
Supply Voltage, Vdc	24 ± 0.5	24 ± 0.5	24 ± 0.5
Current Draw, mA, max.	225	225	600
<b>Performance (35/60MHz of PRN)<sup>7</sup></b>			
Optimum Transmitter Input Level, dBmV/6MHz	6 (-62dBmV/Hz)	6 (-62dBmV/Hz)	6 (-62dBmV/Hz)
Optimum RF Monitor Point Level, dBmV/6MHz	-3 (-71 dBmV/Hz)	-3 (-71 dBmV/Hz)	-3 (-71 dBmV/Hz)
NPR/Dynamic Range, dB <sup>8</sup>	41/12	41/12	35/15
NPR Peak, 35/60MHz Loading, dB <sup>8,9</sup>	48/47	48/47	45/44
BER Dynamic Range			
QPSK @ 10 <sup>-6</sup> , 35/60MHz Load, dB <sup>10</sup>	45/43	45/43	45/43
16-QAM @ 10 <sup>-6</sup> , 35/60MHz Load, dB	35/33	35/33	35/33
<b>EMS Monitor Status</b>			
Laser Shut Down			
Enabled, V	5 ± 0.25	5 ± 0.25	5 ± 0.25
Disable, V	0 + 0.25	0 + 0.25	0 + 0.25

Specification Document Number 601290 Rev H, 601292 Rev H, 601291 Rev J

1. Measured at output of bulkhead connector.
2. Return Loss is specified from maximum gain to 8dB of attenuation.
3. Measured from 5-100MHz.
4. RF testpoint is -9dB referenced to the transmitter input, with transmitter set to maximum gain.
5. Flatness is measured with respect to gain slope. Gain slope is measured as a straight line from 5 to 200MHz.
6. Denotes transmitter temperature. Product must operate in a node from -40 to 60°C.
7. All performance specifications measured while installed in an Opti Max3100 node with a NOR causing low degradation to performance (~-0.5dB).
8. Measured over 6dB fiber link using 35MHz PRN loading.
9. Typical NPR performance measurements taken at room temperature.
10. BER performance is measured with QPSK loading over 6km pure fiber link for a BER of 10<sup>-6</sup>.

## 2:1 Digital Return Processing Module Specifications

Characteristic	Specification <sup>1</sup>
<b>Optical Specifications</b>	
A standard, industrial temperature range DWDM, CWDM, 1310nm, or 1550nm SFP with a data rate of 2.488Gb/s or higher must be plugged into an Opti Max3100 digital processing module	
<b>RF Specifications, each channel</b>	
RF Bandpass, MHz	5 to 42
RF Digitizing Resolution	10 (12 companded)
Data Rate, Gb/s	2.488
Flatness, dB <sup>2</sup>	±0.50
Gain Slope, dB <sup>3</sup>	0±0.25
RF Gain Stability Over Temperature, dB	±1.5
Input and Testpoint Impedance, Ohms	75
Input and Testpoint Return Loss, dB, min.	16
RF Testpoint from Transmitter Input, dB	-9 ± 1.0
<b>LED Indicators</b>	
No optical input signal detected since SFP has been installed	<b>LED State</b> <b>Rx STATUS</b> = Off
Optical input signal detected and lost since SFP has been installed in the module, or optical input signal detected but receiver lock not achieved since SFP has been last installed in the module	<b>Rx STATUS</b> = Solid Red
Optical input signal detected, receiver locked to incoming signal, bit errors detected	<b>Rx STATUS</b> = Flashing Red
Optical input signal present, receiver locked to incoming signal, no bit errors detected	<b>Rx STATUS</b> = Solid Green
Transmitter 1 operating normally	<b>Tx1 STATUS</b> = Solid Green
RF input 1 in over-drive (ADC clipping)	<b>Tx1 STATUS</b> = Flashing Red
Transmitter 2 operating normally	<b>Tx2 STATUS</b> = Solid Green
RF input 2 in over-drive (ADC clipping)	<b>Tx2 STATUS</b> = Flashing Red
No alarms	<b>Rx STATUS, Tx1 STATUS, Tx2 STATUS</b> = Solid green
<b>Powering Specifications</b>	
Power Consumption, W, typ.	5
<b>Temperature Range</b>	
Digital Processing module Operating Temperature, °C (°F)	-40 to 60 (-40 to 140°F)
<b>System Specifications<sup>4</sup></b>	
NPR Peak, dB, typ./min.	50/48
Dynamic Range @ ≥40dB NPR, dB, typ./min.	16.5/15
BER Dynamic Range @ < 10 <sup>-6</sup> BER, dB	28 (64-QAM), 34 (16-QAM), 45 (QPSK)
Link Gain, dB <sup>5</sup>	31
Link Flatness, dB, typ./max.	±0.75/±1.00

- ARRIS guarantees digital return link performance specification only when using an ARRIS supplied SFP.
- Flatness is measured with respect to gain slope.
- Gain slope is measured as a straight line from 5 to 42MHz.
- System specifications with up 100km fiber link.
- With maximum gain at receiver, from input of transmitter to the output of the receiver.

## Opti Max3100 NPR/BER 64-QAM Curve with 2:1 TDM Digital Return Processing Module and SFP

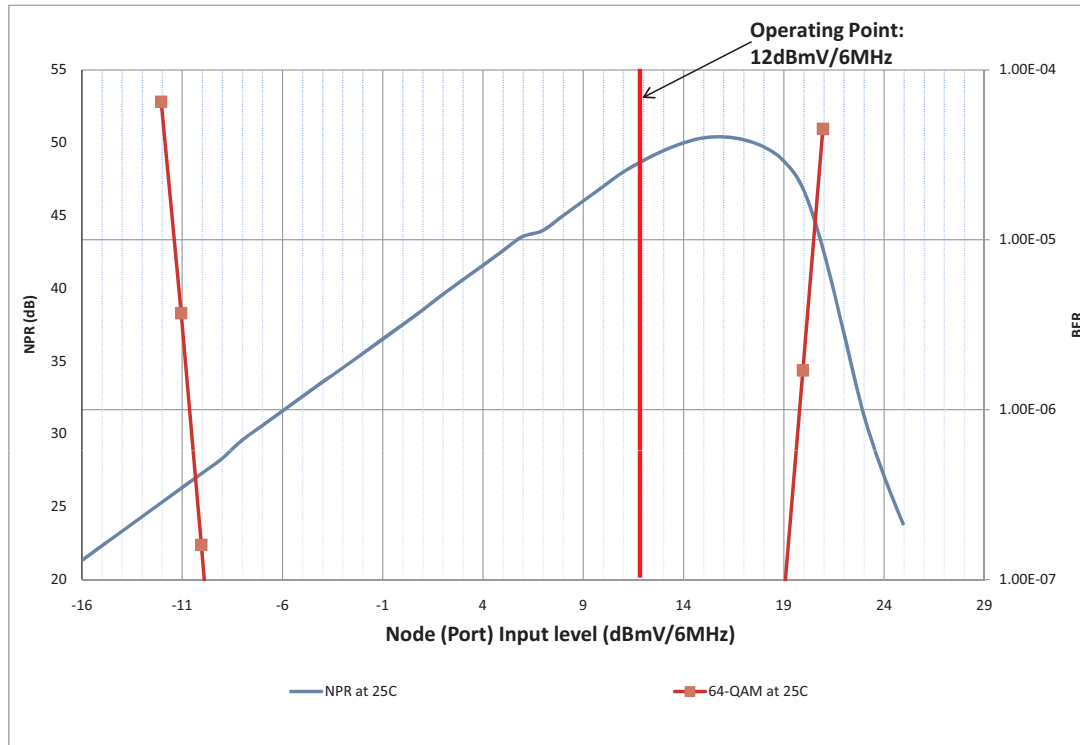

**NPR/BER Curve Obtained Using a 2:1 TDM Digital Return Processing Module Installed in an Opti Max3100 Node with a DWDM SFP through a 100km SMF, and fully loaded from 5 to 42 MHz with six 64-QAM Channels**

Refer to the Opti Max3100 Technical Overview Document (OM3100\_TOD\_date) or the Opti Max3100 Equipment Manual (P/N 1501843) for complete specifications. Specifications are subject to change without notice.

### Opti Max3100 Physical Specifications

Characteristic	Uncrated Measurements	Crated Measurements
Width	15.3 inches (38.9cm)	19.13 inches (48.6cm)
Height	7.9 inches (20.1 cm)	11.63 inches (29.5cm)
Depth	9.1 inches (23.1 cm)	13.2 inches (33.5cm)
Weight	21 pounds (9.5 kg) <sup>1</sup>	22.92 pounds (10.4kg) <sup>1</sup>

1. Approximate weight for a fully-configured node built with two NORs, two NRTs, a Value Max transponder, and appropriate forward configuration module accessories.

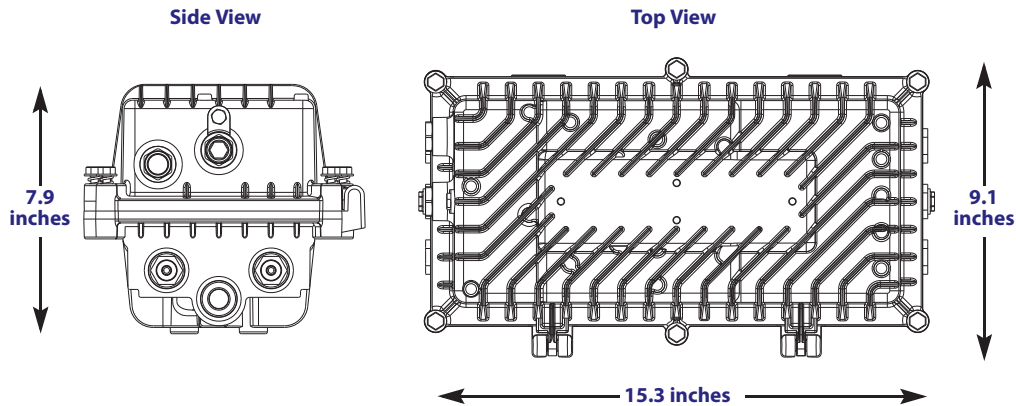

### Ordering Information

To configure a product that meets your specific needs, or for any questions, please contact your ARRIS Sales Professional. You may also use our Product Wizard, located at [support.arrisi.com](http://support.arrisi.com) (User ID and password required). If you do not have a user ID and password or have forgotten your password, please use the Sign In Help section indicated.